

OPERATING INSTRUCTIONS MANUAL

(Please retain for future reference)

For

FVNP-750 INDIRECT FIRED SPACE HEATERS



FOR OUTDOOR AND INDOOR INSTALLATIONS

CERTIFIED FOR USE IN CANADA AND U.S.A.

As per Standard ANSI Z83.7/CSA 2.14 2011 Gas Fired Construction Heaters / Unattended Type.

Issue date July 1, 2012



Intertek
2003325

FLAGRO INDUSTRIES LIMITED
ST. CATHARINES, ONTARIO
CANADA

GENERAL HAZARD WARNING:

FAILURE TO COMPLY WITH THE PRECAUTIONS AND INSTRUCTIONS PROVIDED WITH THIS HEATER, CAN RESULT IN DEATH, SERIOUS BODILY INJURY AND PROPERTY LOSS OR DAMAGE FROM HAZARDS OF FIRE, EXPLOSION, BURN, ASPHYXIATION, CARBON MONOXIDE POISONING, AND/OR ELECTRICAL SHOCK.

ONLY PERSONS WHO CAN UNDERSTAND AND FOLLOW THE INSTRUCTIONS SHOULD USE OR SERVICE THIS HEATER.

IF YOU NEED ASSISTANCE OR HEATER INFORMATION SUCH AS AN INSTRUCTIONS MANUAL, LABELS, ETC. CONTACT THE MANUFACTURER.

WARNING:

FIRE, BURN, INHALATION, AND EXPLOSION HAZARD. KEEP SOLID COMBUSTIBLES, SUCH AS BUILDING MATERIALS, PAPER OR CARDBOARD, A SAFE DISTANCE AWAY FROM THE HEATER AS RECOMMENDED BY THE INSTRUCTIONS. NEVER USE THE HEATER IN SPACES WHICH DO OR MAY CONTAIN VOLATILE OR AIRBORNE COMBUSTIBLES, OR PRODUCTS SUCH AS GASOLINE, SOLVENTS, PAINT THINNER, DUST PARTICLES OR UNKNOWN CHEMICALS.

WARNING:

NOT FOR HOME OR RECREATIONAL VEHICLE USE.

WARNING:

INTENDED USE IS PRIMARILY THE TEMPORARY HEATING OF BUILDINGS UNDER CONSTRUCTION, ALTERATION, REPAIR OR EMERGENCIES ONLY.

This heater is designed and approved for use as a construction heater under Standard ANSI Z83.7/ CGA 2.14. 2011.

We cannot anticipate every use which may be made of our heaters. CHECK WITH YOU LOCAL FIRE SAFETY AUTHORITY IF YOU HAVE QUESTIONS ABOUT APPLICATIONS.

Other standards govern the use of fuel gases and heat producing products in specific applications. Your local authority can advise you about these.

SPECIFICATIONS

Model	FVNP-750 Propane/ Natural Gas
Input	750,000 btuh
Fuel	Propane/ Natural Gas
Manifold Pressure	1.50" W.C. Propane 2.20" W.C. NG
Maximum Inlet Pressure	14.0" W.C. Propane 14.0" W.C. NG
Ignition	Direct Spark Ignition
.....	Thermostat Control
Air Circulation	7000 cfm
Fuel Consumption	37 lbs/hr Propane 806 cfh NG
Approved	cETLus listed

INSTALLATION:

The installation of this heater for use with natural gas shall conform with local codes or, in the absence of codes, with the National Fuel Gas Code ANSI Z233.1/NFPA 54 and the Natural Gas and Propane Installation Code, CSA B149.1. This heater must be installed by a qualified gas technician, following local codes published by the authority having jurisdiction. All installations performed in the state of Massachusetts must be completed by a qualified plumber and gas fitter of the State of Massachusetts.

The installation of this heater for use with propane tank or cylinder shall conform with Local codes or, in the absence of local codes, with the Standard for the Storage and Handling of Liquefied Petroleum Gases, ANSI / NFPA 58 and the Natural Gas and Propane Installation Code, CSA B149.1.

This heater must be located at least 10ft (3m) from any propane gas cylinder. This heater shall not be directed toward any propane gas container within 20ft (6m).

CLEARANCE TO COMBUSTIBLES:

<u>TOP</u>	<u>FRONT</u>	<u>SIDES</u>	<u>REAR</u>	<u>FLUE PIPE</u>
1 ft	1 ft	1 ft	2 ft	2 ft

CONNECTING THE CYLINDER (LP Models only):

The heater must be located at least 6ft (1.83m) in the U.S.; or 10ft (3m) in Canada, from any propane gas container

If cylinders are used to supply the heater, no cylinders smaller than 420lb capacity shall be used. These cylinders must supply a vapor withdrawal only.

1. All cylinder connections must be made using a wrench to tighten the POL fitting.
2. Be sure that the cylinder valve is in the closed position when connection or disconnecting the cylinder.
3. A soap and water solution must be applied to all connections in order to leak check the system.

The gas must be turned off at the propane supply cylinder(s) when the heater is not in use. When the heater is to be stored indoors, the connection between the propane supply cylinder(s) and the heater must be disconnected and the cylinders removed from the heater and stored in accordance with Standard for the Storage and Handling of Liquefied Petroleum Gases, ANSI/NFPA 58 and CSA B149.1, Natural Gas and Propane Installation Code.

PIPING: This heater must be installed by a qualified gas technician following local codes published by the authority having jurisdiction. Sizing of supply piping must be determined using the length of pipe run as well as total btuh rating of the appliance(s). Appropriate piping tables must be used to determine size of supply piping dependant on the length of run from source.

PRESSURES:	MAXIMUM INLET PRESSURES:	LP: 14.0 IN. WC.
		NG: 14.0 IN. WC.
	MINIMUM INLET PRESSURES:	LP: 8.0 IN. WC.
		NG: 7.0 IN. WC.

This heater must be supplied by pressures indicated on the approval label. Over pressure may cause controls to fail.

DO NOT supply this heater with more than ½ psig (14.0 in. W.C.)

Note: A second stage regulator must be installed if the supply pressure exceeds ½ psig.

FUEL: This heater will operate on propane **OR** natural gas. The fuel selector valve must be in the correct position (LP or NG) before operating. The manifold pressures are listed on the approval label. To determine which fuel to use see rating plate. **DO NOT** attempt to use the heater without consulting the rating plate.

HOSES: All hoses used to connect this heater of fuel supply must be Type 1 approved propane / natural gas hose assemblies.

ELECTRICAL:

This appliance is equipped with a grounded receptacle for your protection against shock hazard and should be plugged directly into a properly grounded plug. The electrical grounding of the heater shall be in compliance with the National Electrical Code, ANSI/NFPA 70, or CSA C22.1, Canadian Electrical Code, Part I.

**THIS APPLIANCE IS ABLE TO RECEIVE 1 PHASE OR 3 PHASE POWER.
208V-230V SUPPLY MUST BE AVAILABLE.**

POWER SUPPLY:

**SINGLE PHASE: 208V-230V, 30AMP BREAKER OR 30 AMP TIME DELAY
FUSE, 8/3 AWG AT 100FT MAX.
OR**

**THREE PHASE: 208V-230V, 25AMP BREAKER OR 25AMP TIME DELAY
FUSE, 10/4 AWG AT 100FT MAX.**

****POWER CORD PLUG ENDS PROVIDED WITH UNIT FOR 1 PHASE OR 3
PHASE OPERATION**

This heater is equipped with a VFD "Variable Frequency Drive" to control the primary fan acceleration & de-acceleration. The VFD has been password protected to prevent improper use. If access to VFD controls is required for troubleshooting, please contact manufacture for assistance.

FLUE PIPE: For outdoor applications the flue pipe connection must terminate with a vertical run of at least 2ft complete with rain cap.

For indoor installations the venting must consist of a minimum 2ft vertical run to a maximum of 20ft total vent length. See diagram below for horizontal vent installation.

The vent outlet on the heater is 8" diameter. Certified venting must be used at all times. Vent cap must be installed in situations where downdrafts occur. All venting must correspond with the CSA B149 standard or in its absence, local codes.

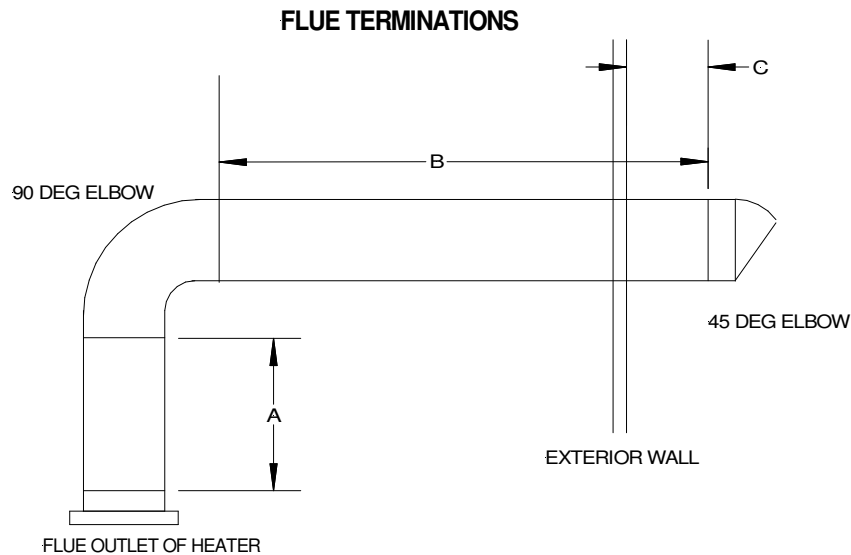

A - Vertical vent run must be a minimum of 2ft from heater outlet.

B - Maximum horizontal run is 20ft
 Note: 90deg Elbow = 5ft

C - Vent termination in horizontal position must be minimum 2ft from wall.
 A 45deg elbow is recommended at horizontal termination.

Note: Horizontal flue run - Rise ratio 1:10.

DUCTING:

OUTLET:

Heater duct with a minimum temperature rating of 300 deg F including wire reinforcement to prevent collapsing must be used. Heater is designed for use with 2 x 16" diameter ducts equipped with Cuff & Buckle (FV-HDG16).

Install ducting to the outlet of the heater using cuff & buckle provided on the collar of the ducting. Ducting should be inspected periodically for tearing and/or wear marks. Ducting should be stored in a dry area when not in use

INLET:

Heater inlet ducting can be used on the FV-750 Series heaters. It is important that you use a Ventflex ducting on in the inlet to ensure the ducting doesn't collapse while in use. Heater is designed for use with 2 x 16" diameter ducts equipped with Cuff & Buckle (FV-HDV16).

MAINTENANCE:

1. **Every construction heater should be inspected before each use, and at least annually by a qualified service person. Incorrect maintenance may result in improper operation of the heater and serious injury could occur.**

2. Service and maintenance should only be done by a qualified service person.

The hose assemblies shall be visually inspected prior to each use of the heater. If it is evident there is excessive abrasion or wear, or the hose is cut, it must be replaced prior to the heater being put into operation. The replacement hose assembly shall be that specified by the manufacturer.

3. The appliance must be kept clear and free from combustible materials, gasoline and other flammable vapors and liquids.
4. The flow of combustion and ventilation air must not be obstructed. Be sure to check the fan assembly and ensure that the motor and blade are operating properly.
5. Compressed air should be used to keep components free of dust and dirt build up. Note: Do not use the compressed air inside any piping or regulator components.
6. High Limit Switches (Part# FV-706 and FV-707) should be checked each season. These limit switches will ensure the burner shuts down if the temperature exceeds 200°F degrees at rear of unit and 250°F at the outlet.
7. Heat Exchanger should be cleaned if smokey conditions continue even after the air adjustments on the burner are made.

START UP INSTRUCTIONS:

1. Position heater properly & on a level surface before operating
2. Connect gas supply to heater (leak test all connections)
3. Ensure the (Thermostat / Manual) selector switch is in the “OFF” position
4. Attach power supply, 208-230V/ 1-Phase or 208-230V/ 3-Phase to proper receptacle.
5. Turn disconnect switch (single or three phase) depending on power supply to “ON” position
6. Move fuel selector valve to correct position – LP or NG
7. Move switch to “MANUAL” position for manual control.

“OR”

8. Move switch to “THERMOSTAT” position for thermostatic control.
9. If the Low Pressure light is illumined on the main panel, you will need to reset the “Low pressure switch button” located on the valve train.

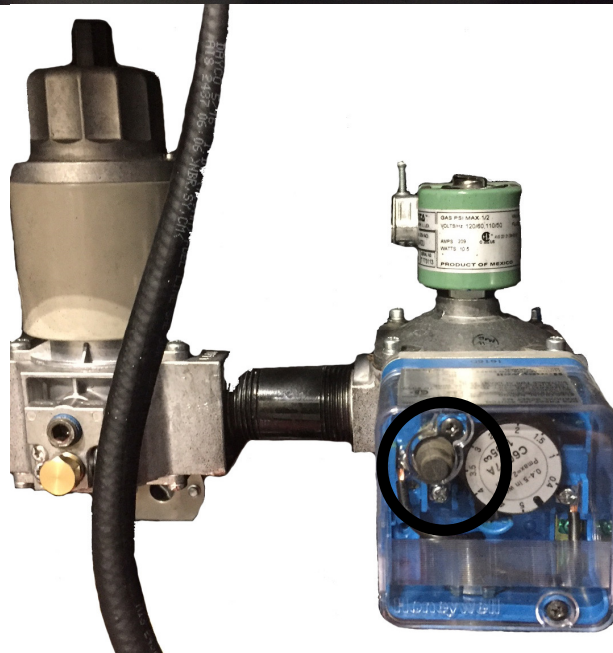
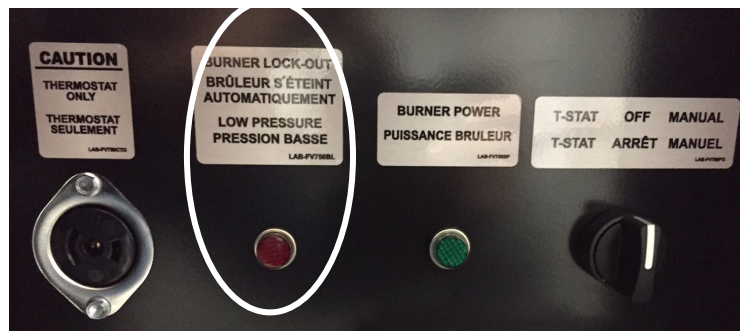

Please Note:

1. If using Thermostat kit, the heater must be started in Thermostat position.
2. When changing between manual and thermostat operation, the heater must be left in the "OFF" position until blower fan completely shuts down before changing position to prevent the burner from locking out.
3. When using a generator for electrical supply, make sure the generator is properly grounded and is at a 60Hz frequency.
4. In the event that a generator is being used and runs out of fuel, make sure the heater switch is in the "OFF" position before restarting generator, failure to do so may damage heater.

TO SHUT DOWN:

1. Close main gas supply valve.
2. Move Thermostat/Manual switch to "OFF" position.
3. Waiting until blower fan shuts down (3 minutes approx.)
4. Move Disconnect switch (single phase or three phase) depending on power supply to "OFF" position.
5. Turn main breaker to "OFF" position
6. Disconnect heater from gas supply.

IF HEATER FAILS TO START:

1. Press manual reset button at rear of burner.
2. Check gas pressure supply. Supply and manifold pressure must follow those on rating plate.
3. Ensure proper power supply is being used.
4. If heater fails to ignite after 3 attempts, **call your supplier for service.**

SAFE OPERATION PRECAUTIONS:

1. For use with propane or natural gas only. Fuel sector valve must be in correct position. See approval label.
2. Use Thermostat/Manual switch to shut down the heater. Do not try to shut down the heater by the disconnect switches or unplugging the electrical cord.
3. Do not plug anything other than the thermostat into the "Thermostat" plug.
4. Follow electrical requirements shown on rating plate and/or Electrical requirements section of this manual.
5. Before removing any guards or performing any maintenance, be sure that the main power supply is disconnected.
6. The hose assembly shall be protected from traffic, building material & contact with hot surfaces, both during use & while in storage

COMBUSTION AIR ADJUSTMENTS:

NOTE: Proper combustion air adjustment must be achieved using a certified combustion analyzer to ensure complete combustion.

The air adjustment should be made to achieve 10% CO₂ on natural gas and 12% CO₂ on propane.

SETTING THE AIR ADJUSTMENT PLATE

A) Regulation of the combustion air flow is made by adjustment of the manual AIR ADJUSTMENT PLATE (1) after loosening the FIXING SCREWS (2 and 3). The initial setting of the air adjustment plate should be made according to Column 3 in the Burner Set-up Chart.

B) The proper number on the manual AIR ADJUSTMENT PLATE (1) should line up with the SETTING INDICATOR (4) on the fan housing cover. Once set, the air adjustment plate should be secured in place

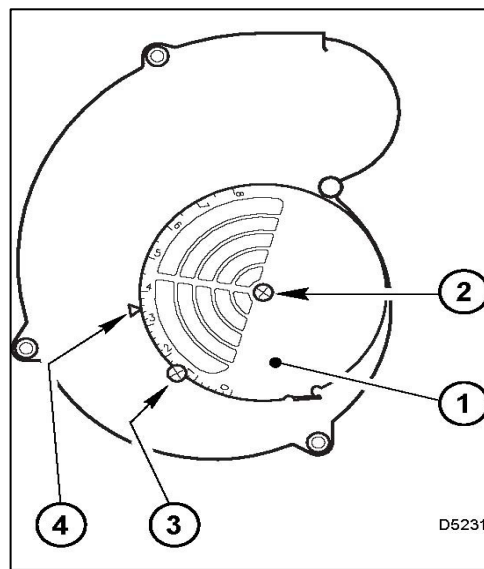

by tightening SCREWS 2 and 3.

C) The final position of the air adjustment plate will vary on each installation. Use instruments to establish the proper settings for maximum CO₂.

NOTE: Variations in flue gas, CO₂ and temperature readings may be experienced when the burner cover is put in place. Therefore, the burner cover **must** be in place when making the final combustion instrument readings, to ensure proper test results.

BURNER SET-UP CHART

1	2	3
FIRING RATE (BTUH)	HEAD SETTING	AIR DAMPER SETTING
750,000	4.0	4.5

BURNER COMPONENTS IDENTIFICATION

- 1 Air damper
- 2 Servomotor
- 2 Motor
- 4 Air pressure switch
- 5 Wiring terminal block
- 6 Control box RMG 88.62
- 7 Reset button with lock-out lamp

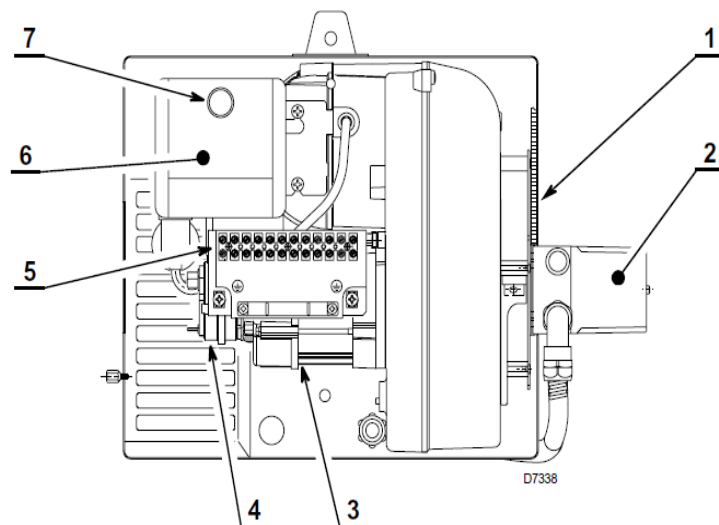

*****Please Note: FVN/P-750 is not equipped with the “servomotor”.**

BURNER DIMENSIONS

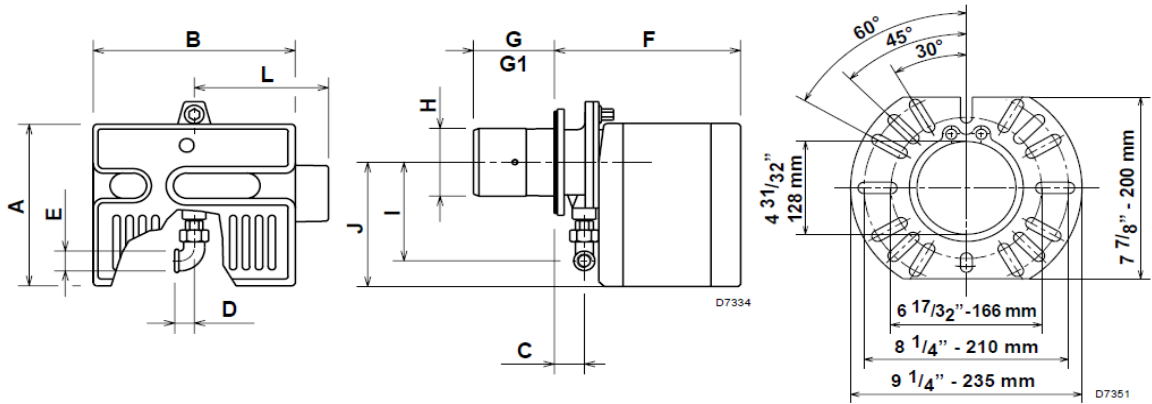

Model 900	A	B	C	D	E	F	G	G1	H	I	J	L
inches	11 ⁴⁷ / ₆₄	13 ²⁵ / ₃₂	2 ⁴¹ / ₆₄	1 ¹⁹ / ₆₄	³ / ₄	15 ²³ / ₆₄	4 ²³ / ₃₂	10 ⁵ / ₈	4 ⁵⁹ / ₆₄	5 ⁶³ / ₆₄	9 ¹ / ₁₆	3 ⁴⁷ / ₆₄
mm	298	350	67	33	19	389	120	270	125	152	230	95

NOTE: Actual available insertion length must be measured from tip of end cone to face of mounting gasket.

ELECTRODE AND FLAME PROBE ADJUSTMENTS

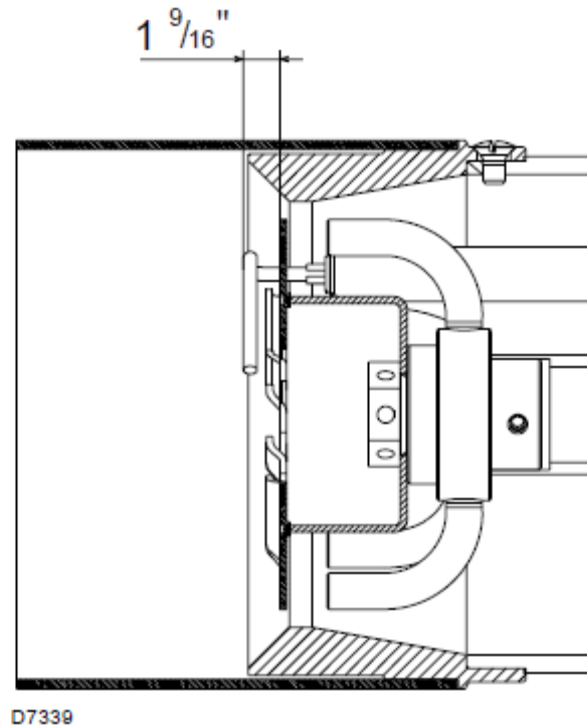

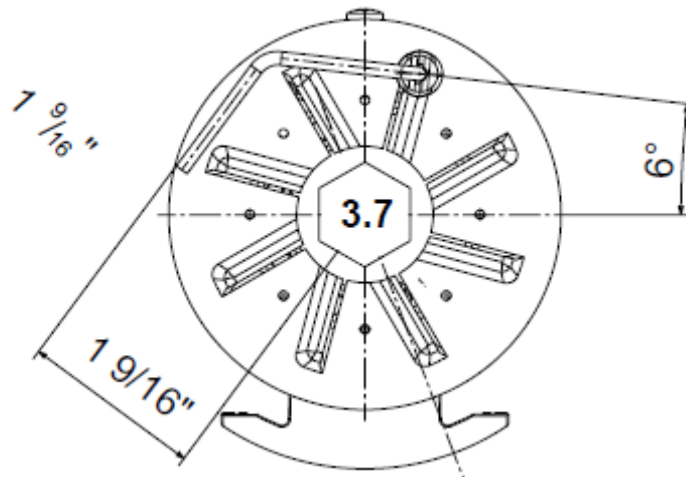

IMPORTANT: Do not turn the ignition electrode. Leave it as shown in the drawing. If the ignition electrode is put near the ionization probe, the amplifier of the control box may be damaged.

TYPICAL GAS TRAIN LAYOUT

This gas train scope of supply meets the minimum controls requirements according to CGA and AGA regulations. Any additional requirements needed to meet local codes are the responsibility of others.

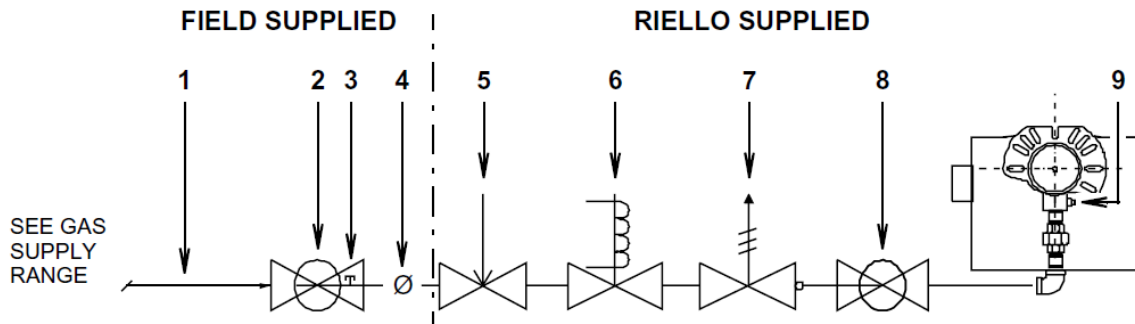

NOTE: ITEMS 5, 6 & 7 COMBINATION GAS VALVE(S) ASSEMBLIES MAY BE UTILIZED WHERE APPROVED

- 1 - GAS SUPPLY & FLOW DIRECTION OF GAS
- 2 - GAS SUPPLY MAIN SHUTOFF MANUAL VALVE (FIELD SUPPLIED)
- 3 - GAS SUPPLY PRESSURE TEST POINT (FIELD SUPPLIED)
- 4 - GAS TRAIN PIPE DIAMETER SIZE(S):
BURNER G900 1" NPT (REDUCED AT COMBUSTION HEAD TO 3/4")
- 5 - GAS APPLANCE PRESSURE REGULATOR
- 6 - SAFETY SHUTOFF GAS VALVE (VS) 120v OPERATED
- 7 - MAIN GAS VALVE 120V OPERATED
BURNER G750 = TWO STAGE V1 - V2
- 8 - FIRING VALVE MANUAL SHUTOFF
- 9 - GAS BURNER MANIFOLD TEST POINT

GAS SUPPLY PRESSURE RANGES:

NATURAL GAS PRESSURE:
min. 7" wc - max. 14" wc

LP PROPANE GAS PRESSURE
min. 8" wc - max. 13" wc

WIRING DIAGRAM

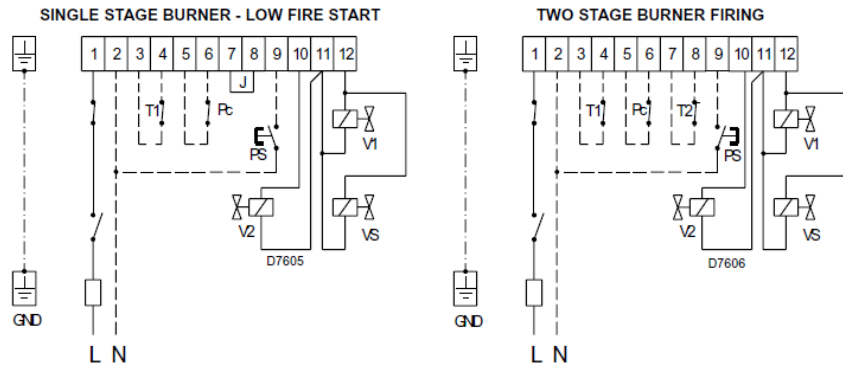
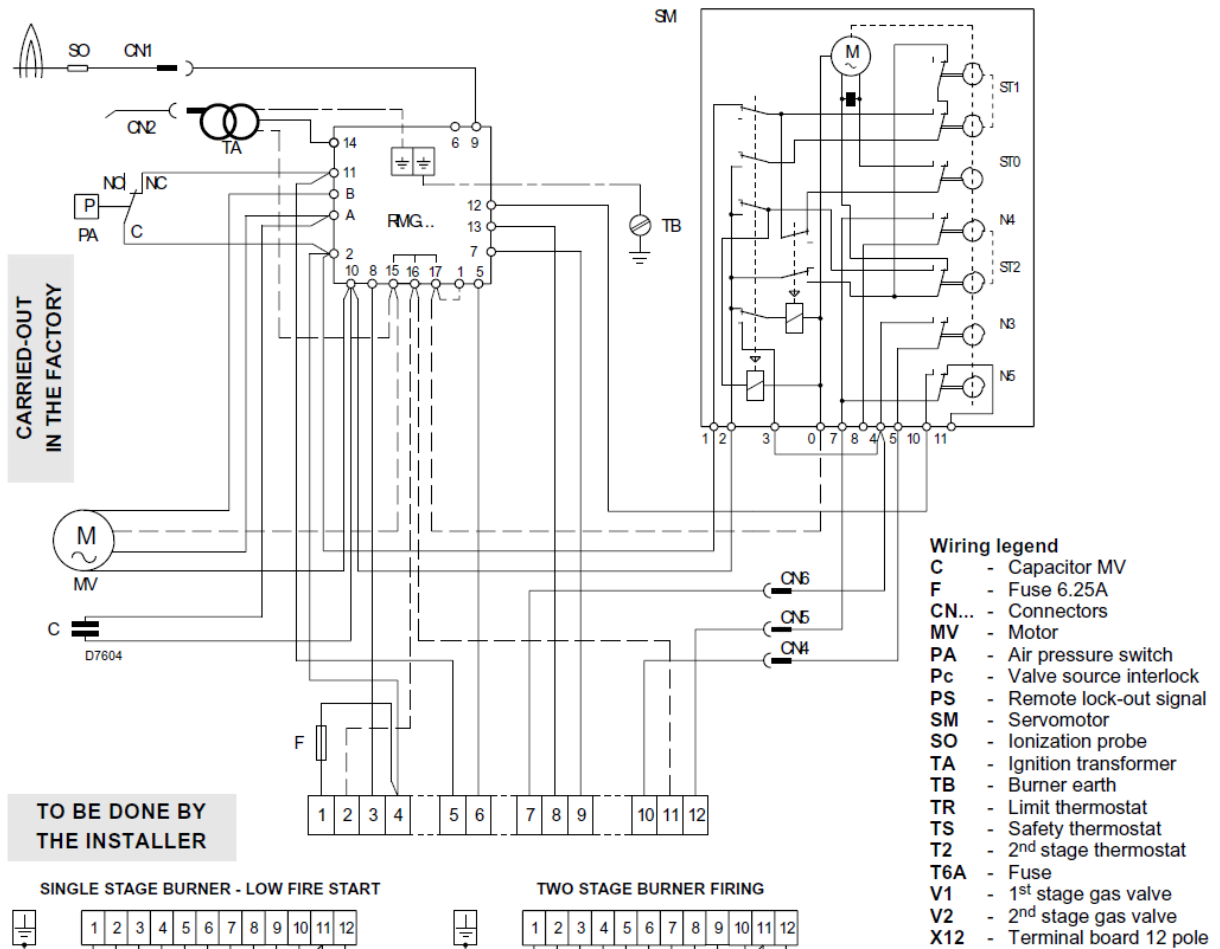

Note: If an external electrical source is utilized, the conversion burner, when installed, must be electrically grounded with a solid green wire to Earth Ground, in accordance with local codes or, in the absence of local codes, with the National Electrical Code ANSI/NFPA 70-1990 and the CSA Electrical Code.

CONTROL CIRCUITS

Burner firing stage may be controlled by either a 120V or 24V control system. The required controls must be connected to the burner as described on the following pages.

120V CONTROL SYSTEM

First stage firing is controlled by a 120V operating control wired between terminals 3 and 4 on the terminal block. To control second stage fire on demand only, a second 120V control must be wired between terminals 7 and 8 after removing the factory-installed jumper.

*****Please note: FVN/P-750 is a single stage burner only.**

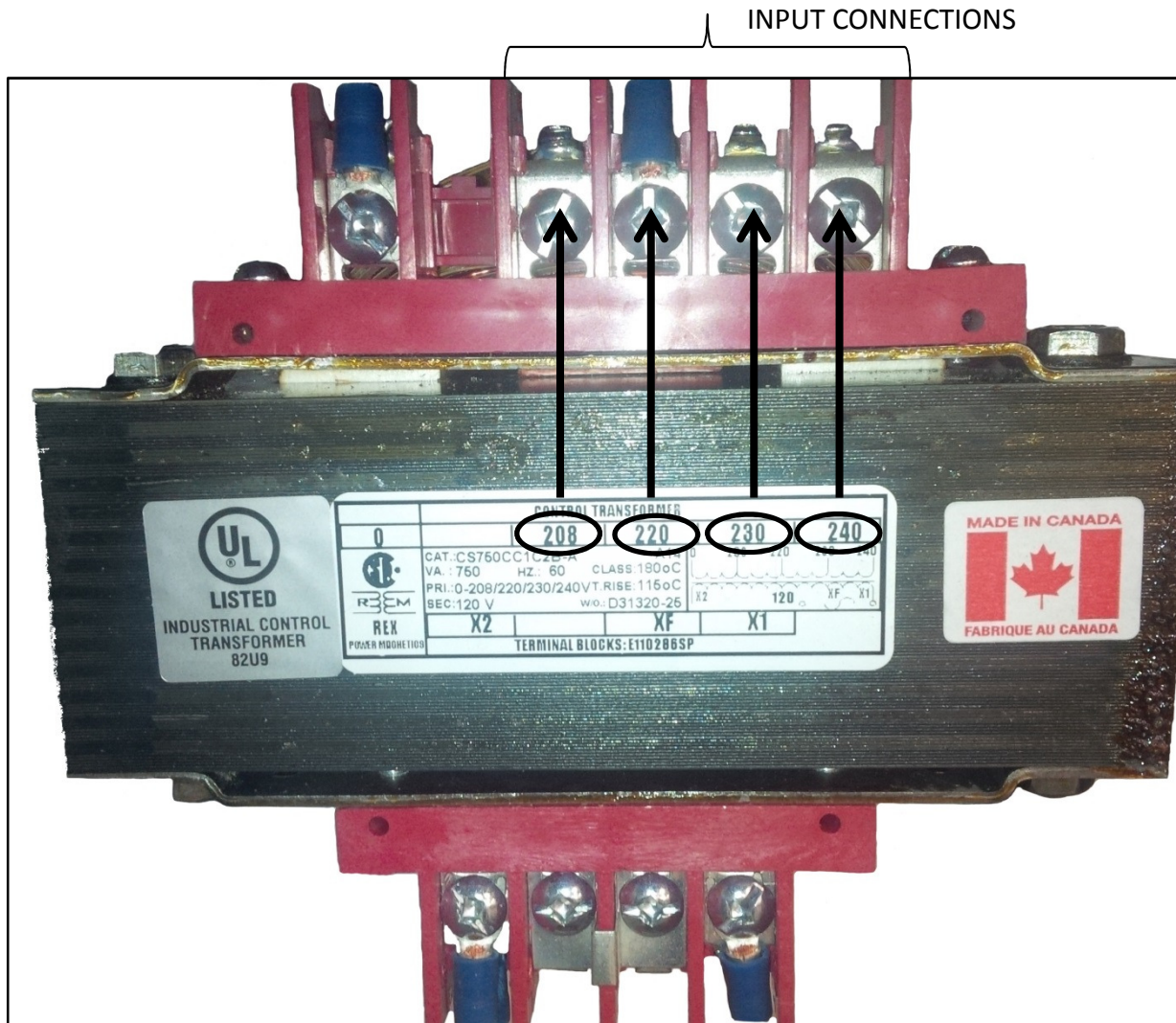

**TRANSFORMER OFFERS 4 DIFFERENT INPUT POWER SUPPLY OPTIONS
FACTORY SET AT 220V.
IT IS IMPORTANT TO CHANGE YOUR INPUT CONNECTION BASED ON YOUR
POWER SUPPLY, AS THE BURNER WILL NOT OPERATE PROPERLY**

G900 DUAL FUEL LP/NG BURNER - PARTS DIAGRAM

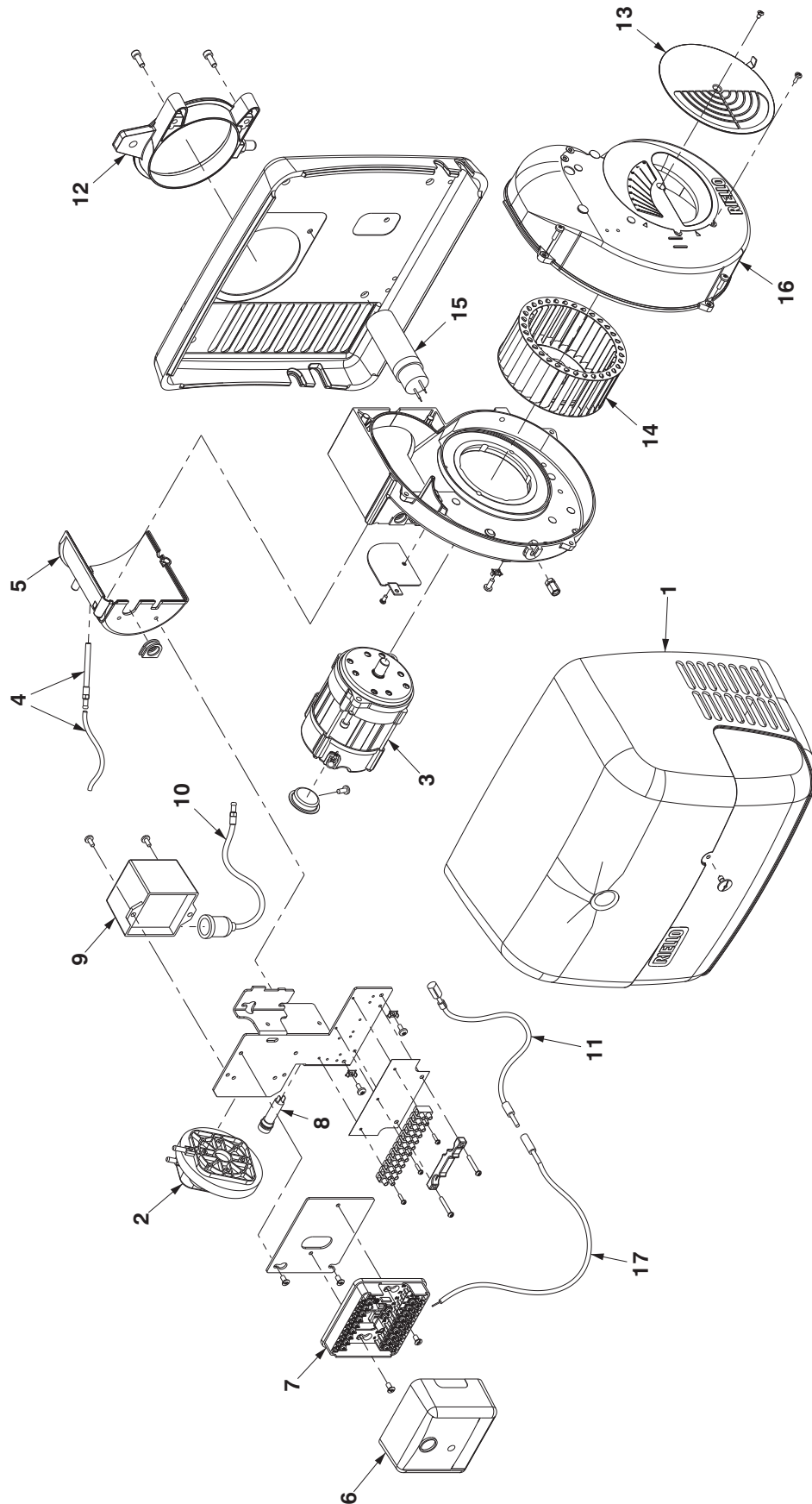

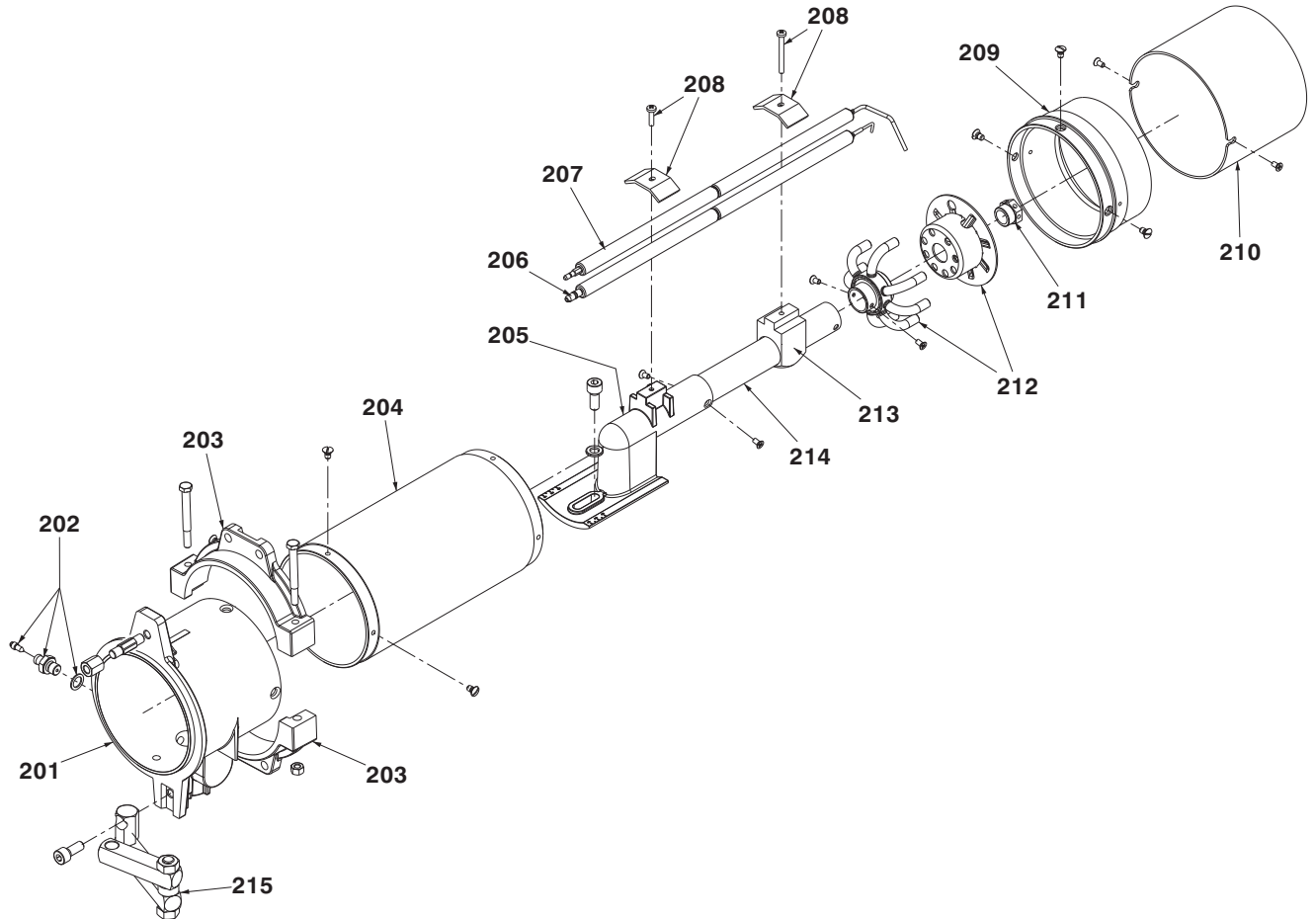

RIELLO BURNER G900 - PARTS LIST DIAGRAM

N#	PART NUMBER	DESCRIPTION
1	FV-20137281-LPNG	PLASTIC BURNER COVER C/W LABELS
2	FVNP-3020321	AIR PRESSURE SWITCH
3	FV-3005845	BURNER MOTOR
4	FVNP-3007288	AIR SWITCH TUBE & CONNECTOR
5	FVNP-3007294	AIR COVER
6	FVNP-3013072	IGNITION MODULE
7	FVNP-3003784	IGNITION MODULE SUB-BASE
8	FVNP-3006804	FUSE 6.25 AMP
9	FVNP-3002462	IGNITION TRANSFORMER
10	FVNP-3002461	HIGH VOLTAGE LEAD
11	FVNP-3007310	IONIZATION LEAD
12	FVNP-3006689	CHASSIS MOUNTING COLLAR
13	FVNP-3007206	AIR DAMPER
14	FV-3005799	BURNER FAN
15	FVNP-3007307	BURNER CAPACITOR
16	FVNP-3007210	AIR INTAKE
17	FVNP-20137439	LEAD
201	FVNP-3007526	MANIFOLD - LONG
202	FVNP-3005447	GAS PRESSURE TEST POINT ADAPTER
203	FVNP-3005849	SEMI FLANGE
204	FVNP-3007286	AIR TUBE - LONG
205	FVNP-3006697	DRAWER ASSEMBLY ELBOW
206	FVNP-3006962	ELECTRODE ASSEMBLY
207	FVNP-3020210	FLAME ROD
208	FVNP-3003409	ELECTRODE & IONIZATION CLAMP
209	FVNP-3007283	COMBUSTION HEAD CONNECTOR
210	FVNP-3006694	END CONE
211	FVNP-3006703	MAIN ORIFICE
212	FVNP-3006700	DISTRIBUTOR HEAD & MIXING PLATE
213	FVNP-3007314	ELECTRODE SUPPORT
214	FVNP-3007313	NATURAL GAS TUBE
215	FVNP-3000870	HINGE ASSEMBLY



26 Benfield Drive , St.Catharines Ontario Canada
905-685-4243
12949 Eagle Creek Parkway, Savage MN USA
866-266-2484

FV-750– PARTS LIST

BOLT ON HINGE



FV-726

REAR DOOR LATCH



FV-725

HIGH LIMIT



**FV-706 – 250F
FV-707 – 200F**

THERMOSTAT



FV-414B

GREEN LIGHT



S-1020C

RED LIGHT



S-1020B

3 POSITION SWITCH



FV-712

**ON/OFF POWER SWITCH
3 PHASE & 1 PHASE**



**FV-731 – 3 PHASE
FV-732 – 1 PHASE**

**3 PHASE & 1 PHASE
RECEPTACLE**



**FV-730 – 1 PHASE
FV-730A - COVER
FV-729 – 3 PHASE**

FV-750 PARTS LIST

3 PHASE/1 PHASE PLUG END



**FV-727 – 3 PHASE
FV-728 – 1 PHASE**

15 H.P. VFD



FV-703

750V TRANSFORMER



FV-704

POWER RELAY



FV-734 – POWER RELAY

15 AMP BREAKER



FV-722

**6AMP FUSE/2 POLE CLASS
CC FUSE HOLDER**



**FV-708 – 6 AMP FUSE
FV-709 – 2 POLE HOLDER**

CONTACTORS/BLOCK



FV-720 – 7.5 HP contactor (2 BASE)

**FV-721 - AUXILIARY CONTACT
BLOCK (TOP RIGHT SIDE)**

GROUND LUG



FV-714

FV-750 PARTS LIST

7.5 H.P. FAN MOTOR



FV-701

BLOWER ASSEMBLY



FV-702

FV-750 BURNER PARTS LIST - OIL

IGNITION CONTROL



FV0-C700-1029

PHOTO CELL



FV0-20132573

FUEL PUMP



FV0-20062453

FAN MOTOR



FV-3005845

ELECTRODE ASSEMBLY



FV0-3005903

OIL NOZZLE



FV-733 (4.50 X 60W)

COIL



FVO-3002279

TIGER LOOP SYSTEM



FVO-TLSF

BURNER COVER



FV-20137281- OIL

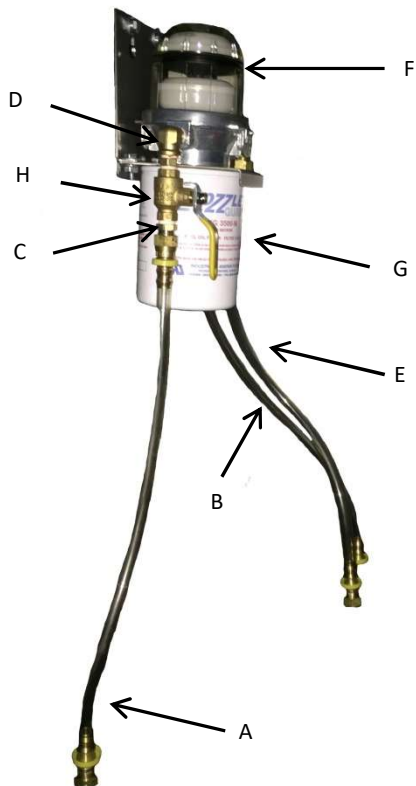

DIESEL FILTER SYSTEM

- | | |
|-----------------------|------------------------------------|
| A – FVO-735 | FUEL SUPPLY TO TIGER LOOP |
| B – FVO-738 | FUEL RETURN LINE |
| C – 48-6C | BRASS FITTING |
| D – 49-6C | ELBOW |
| E – FVO-737 | FUEL LINE, FILTER TO BURNER |
| F – FVO-734 | TIGER LOOP |
| G – FVO-TLSF | FILTER |
| H – 2103-C-CGA | SHUT OFF VALVE |

FV-750 BURNER PARTS LIST – LP/NG

ELECTRODE



FVNP-3006962

FLAME ROD



FVNP-3020210

AIR PRESSURE SWITCH



FVNP-3020321

BURNER ORIFICE



FVNP-3006703

BURNER COVER



FV-20137281-LPNG

BURNER MOTOR



FV-3005845

IONIZATION LEAD



FVNP-3007310

IGNITION MODULE



FVNP-3013072

GAS SELECTOR VALVE



2103-F-CGA (1")

ON/OFF VALVE



2103-E-CGA (3/4")

BODY PANELS



<u>P/N</u>	<u>DESCRIPTION</u>
FV750-840	LID
FV750-824	RIGHT SIDE CENTRE PANEL
FV750-823	LEFT SIDE CENTRE PANEL
FV750-828	RIGHT SIDE FRONT PANEL
FV750-827	LEFT SIDE FRONT PANEL -INLET
FV750-835	LEFT SIDE REAR PANEL
FV750-834	RIGHT SIDE REAR PANEL
FV750-837	REAR ACCESS DOOR
FV750-829	FRONT OUTLET PANEL

PARTS LIST FOR FVN/P-750 SERIES

Part Number	Part Description
FV-701	7.5 HP PRIMARY FAN MOTOR
FV-702	BLOWER ASSEMBLY
FV-703	15 HP VFD
FV-704	750VA TRANSFORMER
FV-705	SS HEAT EXCHANGER
FV-706	HIGH LIMIT (OUTLET) 250F
FV-707	HIGH LIMIT (REAR) 200F
FV-708	3.5 AMP CLASS CC FUSE (TWO PER HEATER)
FV-709	2 POLE CLASS CC FUSE HOLDER
FV-712	3 POSITION SWITCH (MANUAL-OFF-THERMOSTAT)
FV-410	GREEN (POWER ON) LIGHT
FV-411	RED (BURNER LOCK OUT) LIGHT
FV-414B	THERMOSTAT RECEPTACLE
FVNP-713	RIELLO BURNER (LP/NG) G900
FV-714	GROUND LUG
FV-717	DIN RAIL MOUNT TERMINAL BLOCK (FIVE PER HEATER)
FV-718	DIN RAIL MOUNT TERMINAL BLOCK END
FV-719	END STOP FOR DIN RAIL
FV-720	7.5 HP CONTACTOR
FV-721	AUXILLARY CONTACT BLOCK
FV-722	DIN RAIL MOUNT 15AMP BREAKER
FV-723	MOUNTED ELECTRICAL ENCLOSURE
FV-724	BACK PANEL FOR ELECTRICAL ENCLOSURE
FV-725	REAR DOOR LATCH (INCLUDES MOUNTS & RAILS)
FV-726	DOOR HINGE (TWO PER HEATER)
FV-727	3 PH 30AMP PLUG END
FV-728	1 PH 50AMP PLUG END
FV-729	3 PH 30AMP RECEPTACLE
FV-730	1 PH 50AMP RECEPTACLE
FV-730A	1 PH 50AMP RECEPTACLE COVER
FV-731	3 PH (ON/OFF) DISCONNECT BOX
FV-732	1 PH (ON/OFF) DISCONNECT BOX

FV-734	POWER RELAY
FVNP-739	1" NPT FUEL SELECTOR VALVE
FVNP-740	1" NPT SHUT OFF VALVE (TWO PER HEATER)
FV-446	SIGHT GLASS C/W FIBER GASKET
FV-447	SIGHT GLASS WASHER

ACCESSORIES	
FV-HDG16	16" X 25FT HITEX OUTLET DUCTING
FV-HDV16	16" X 25-FT VENTFLEX INLET DUCTING
FV-THB	THERMOSTAT C/W 25FT CORD/MALE PLUG END
FV-THB(15M)	THERMOSTAT C/W 50FT CORD/MALE PLUG END
FV-VKA	8" X 2.5FT C-VENT C/W RAIN CAP

THREE PHASE
POWER DISCONNECT

SINGLE PHASE
POWER DISCONNECT

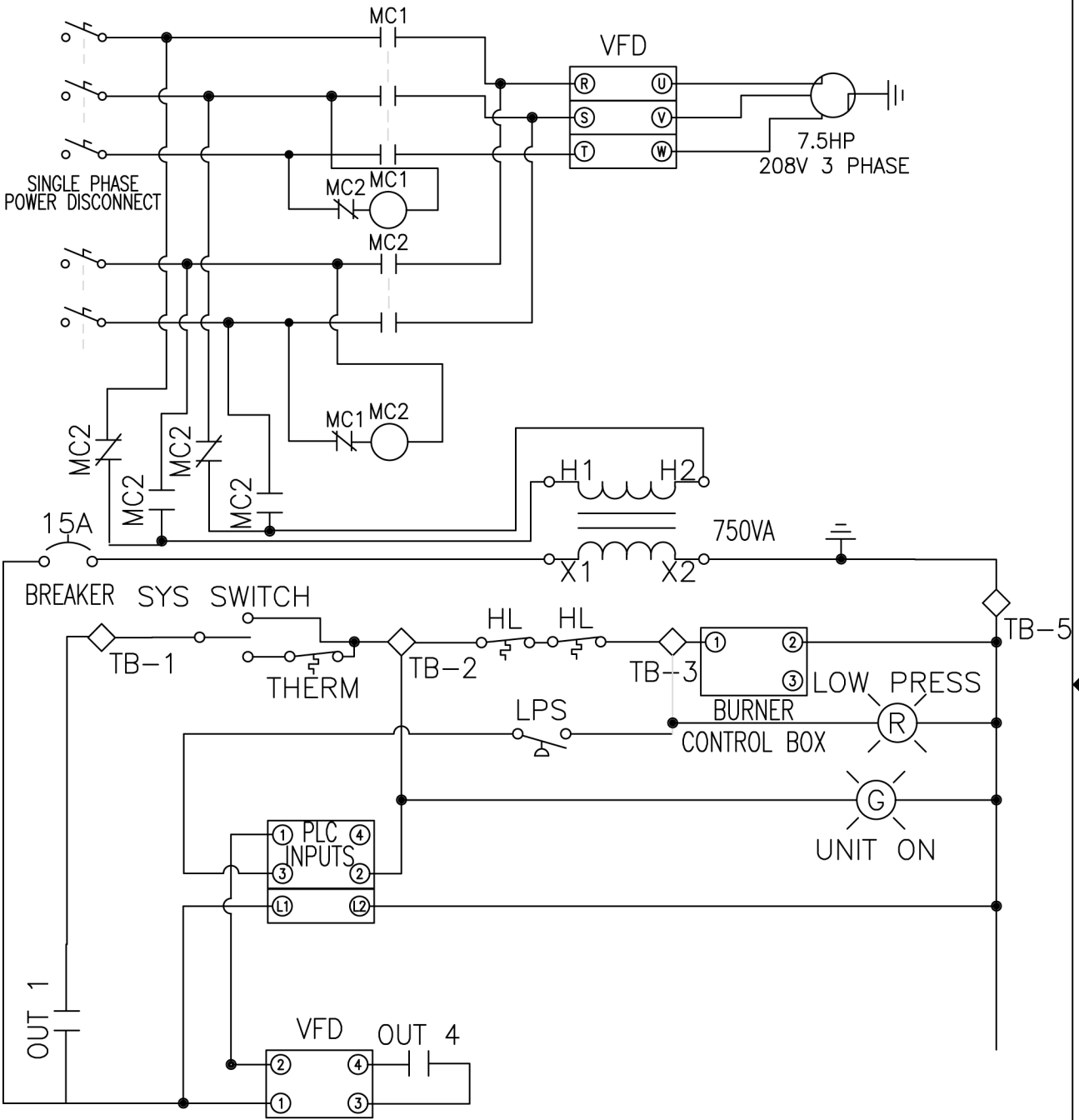

FLAGRO INDIRECT HEATER

FVNP-750

SIZE N/A	FSCM NO	DRAWING NUMBER 0001	REV 1.03
SCALE N/A	SHEET N/A		